

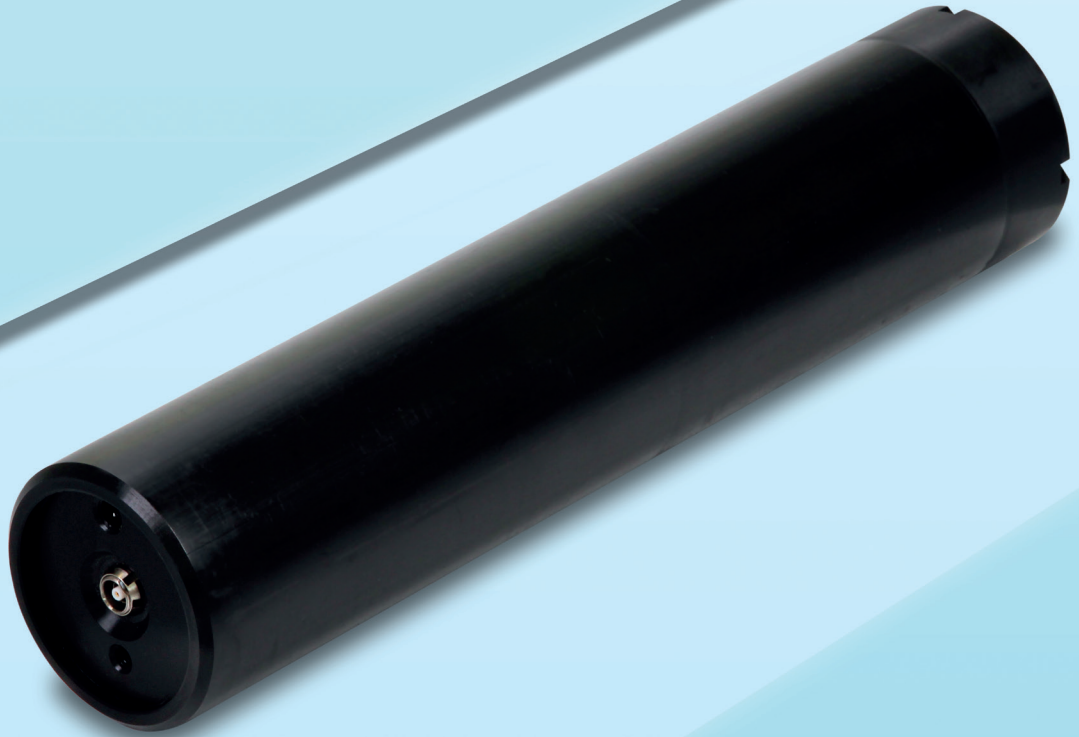





# DM Series



## Data Sheet **DM-060**

	<b>CONTENT</b>
	<i>System Overview</i>
	<i>Highlights</i>
	<i>Technical Data</i>
	<i>Illustrations and Figures</i>





# System Overview

The Digital Magnetometers of the DM Series is based on STL's unrivalled high resolution ADC technology with 32 bit resolution and 26 bit dynamic range. The magnetometers use fluxgates as their magnetic sensitive elements and have integrated DXS. As a result of consequent digital signal processing, our magnetometers are quasi ideal sensors with digitally corrected geometry and temperature errors.

The DM Series provides a measurement range of up to 1 mT, with an ultra precise digitization taking place immediately after the sensor output. All magnetometers measure the 3 orthogonal field components with a maximum sample rate of 10 kHz and offer very low intrinsic noise from 60 pT/ $\sqrt{\text{Hz}}$  @ 1 Hz down to 6 pT/ $\sqrt{\text{Hz}}$  @ 1 Hz.

The software also offers the total field as an extra virtual channel. Typical error sources like axes misalignment, scaling, offset and phase errors are eliminated to the greatest possible extent due to its consequent digital signal conditioning strategy. In addition the temperature is measured intrinsically and used to correct for scaling and offset drifts.



## Highlights of the DM Series

- Very low noise, large dynamic range and high linearity
- Digital temperature compensation for minimizing of drifts
- Sensor output digitally error corrected with respect to scaling, offset, orthogonality and alignment
- Single coaxial cable for power and data transmission introduces minimal magnetic signature
- Unlimited field of application; geophysical, naval, military or scientific purposes in general are possible



# Technical Data Type „DM-060“

<b>Number of Channels</b>		3
<b>Diameter</b>		63 mm
<b>Length</b>		300 mm
<b>Weight</b>		1.4 kg
<b>B<sub>max</sub> (μT)</b>	<b>Noise (pT/√Hz)</b>	<b>Resolution (pT)</b>
± 70	-	-
± 80	-	-
± 100	-	-
± 250	< 60	0.5
± 500	< 60	1
± 1000	< 60	2
± 2000	< 120	2
<b>Sample rate</b>		0.1 Hz – 10 kHz in 1,2,5,10 pattern
<b>Digital filter</b>		0 dB @ DC – f <sub>s</sub> /3, < -120 dB @ ≤ f <sub>s</sub> /2
<b>Max. Bandwidth</b>		4 kHz
<b>Offset error (25 °C)</b>		< 10 nT
<b>Offset drift (25 °C)</b>		< 0.5 nT/°C
<b>Scaling error (25 °C)</b>		< 0.05 %
<b>Scaling drift (25° C)</b>		< 5 ppm/°C
<b>Orthogonality error</b>		< 0.01°
<b>Isogeometric error</b>		< 8 mm
<b>Housing alignment error</b>		Longitudinal axis: < 1°
<b>Power consumption</b>		< 3 W
<b>Degree of protection</b>		- IP65, IP68 on request - Underwater tight, depth on request
<b>Temperature range</b>		-5° to 50°
<b>Optional equipment</b>		- Tilt sensor for compass with self alignment - Underwater case



# Illustrations and Figures

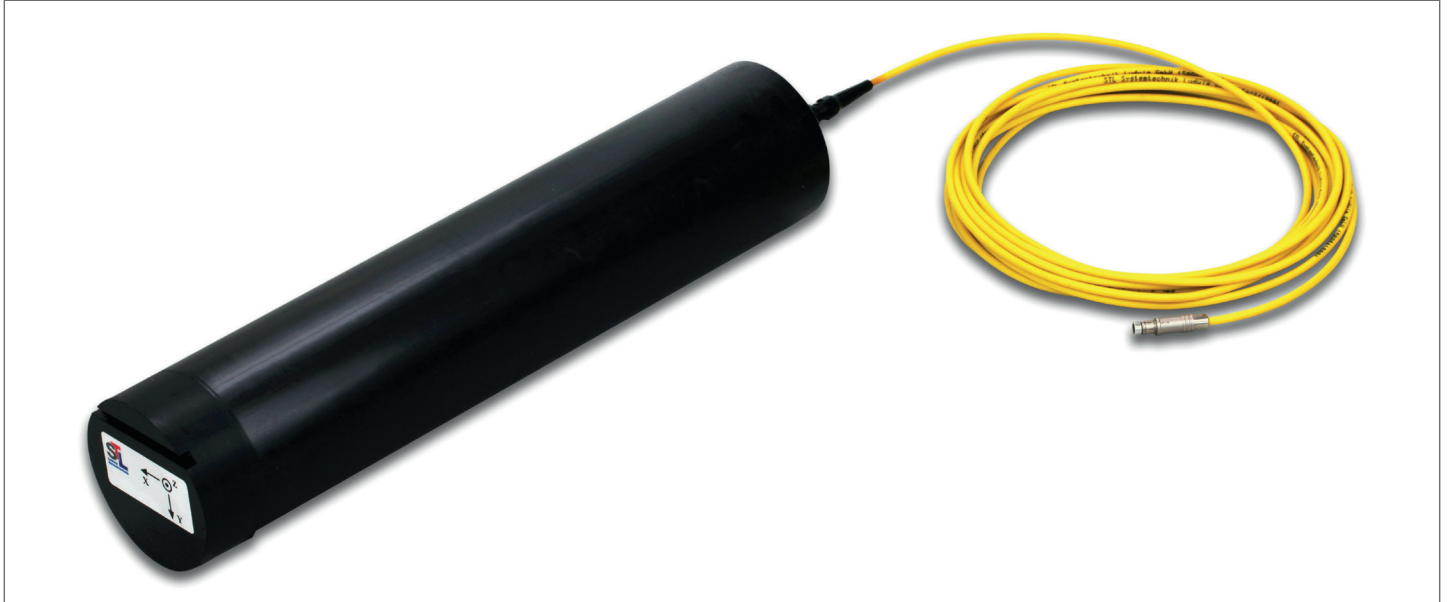

DM-060 with coaxial cable (included)



DM-060 sideview

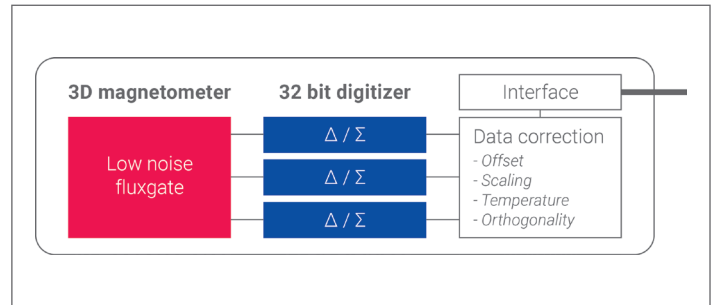

Functional overview

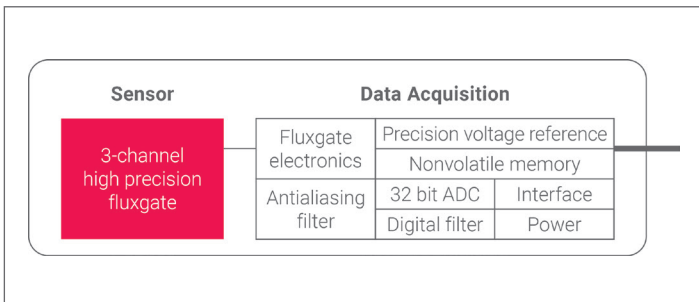

Sensor concept

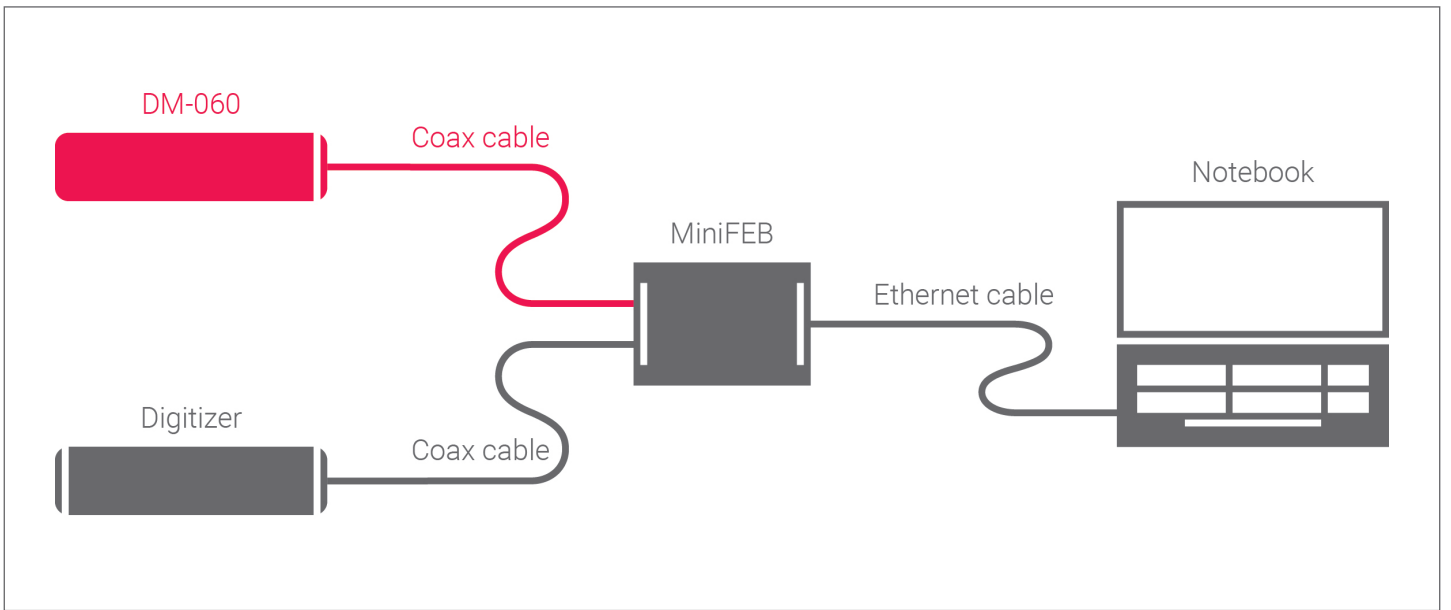

Component scheme